

MODEL JS

A snap-action, self-hold thermostat for motor and appliance applications. In a fault condition, the Model JS opens the circuit, and an internal heat source holds it open until power is removed and the unit is allowed to cool. The thermostat then resets, allowing continued operation.

FEATURES

- Snap-action device for quick break switching action.
- Internal heat source provides a low profile design for better fit into tight spaces.
- Self-hold functionality available for both 120 VAC and 240 VAC applications.
- Conductive bimetal construction; the bimetallic element carries the circuit current for maximum current sensitivity. Various resistances of bimetal available.
- Preset calibration temperature; not adjustable in the field.
- Case electrically alive; insulating sleeving available.
- Available with or without factory applied lead wires.

CONTACT RATINGS

- Underwriters Laboratories (CUL Rated)
 - **Temperature Indicating & Regulating Equipment**
120VAC/15A Resistive (1800 Watts) 6000 Cycles
 - **Component Motor Protective Devices**
120VAC/15A 240VAC/10A (Suggested Ratings)
- International Electrotechnical Commission (IEC)
 - **Automatic Electrical Controls for Household & Similar Use**
 - **Thermal Motor Protectors**
 - **Temperature Sensing Controls**
250VAC/13A (Res), 5A (Ind.) 10,000 Cycles
- VDE
 - **Thermal Motor Protector**
 - **Temperature Sensing Control**
250 VAC 13A (Res.), 5A (Ind.) 10,000 Cycles

CALIBRATION TEMPERATURE RANGE

- Available with nominal calibration temperatures from 60°C to 160°C.

We come through when the heat is on™

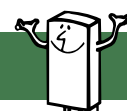

Pepi®

Portage Electric Products, Inc.



TOP VIEW

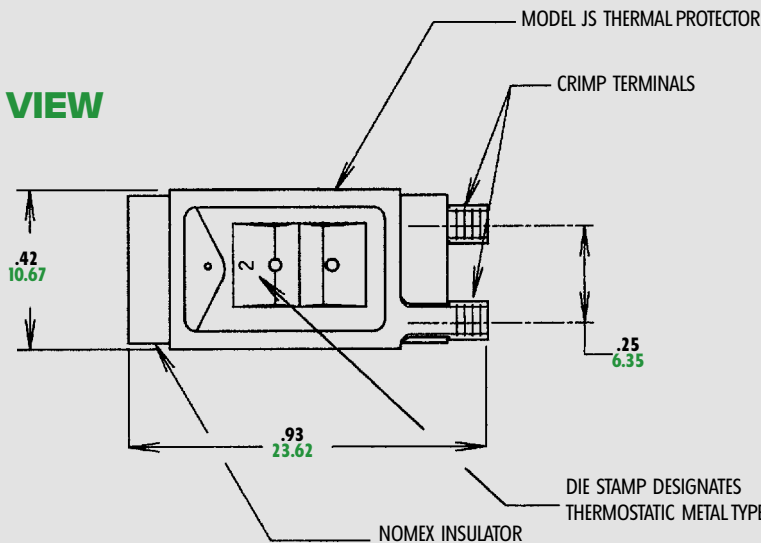

SIDE VIEW

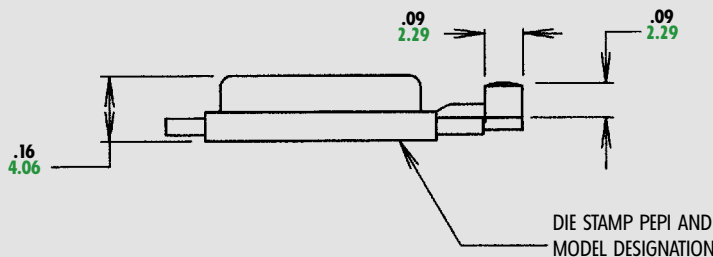

METRIC DIMENSIONS ARE IN MM (SHOWN IN GREEN)

Copyright 2006, Portage Electric Products, Incorporated, all right reserved